



Before proceeding, please do the following:

- 1. Assemble the Cart:** Use the “Cart Assembly” instructions on the following pages.
- 2. Place Machine on Cart.** Use the handles included with the shipment. Refer to the instructions in the following pages.
- 3. Attach the User Interface Assembly & X-Beam End Caps.**
Refer to the instructions in the following pages.
- 4. Install Melco Operating System Software.**
Refer to the instructions in the following pages.
- 5. Follow the steps in the Help Document:**
Part 1 of the manual contains instructions for machine setup from connecting the power cord through threading the machine.

Page intentionally left blank

Page intentionally left blank

Cart Assembly

The cart consists of the following listed items. To assemble, use the 4mm hex wrench included in your Machine Operator's Kit.

Item	Qty	Description
A	1	Left Cart Leg Assembly
B	1	Right Cart Leg Assembly
C	1	Cart Base Support
D	1	Cart Rear Support
E	14	M6 x 12mm Button Head Screw
F	18	M6 Flat Washer
G	1	Cart Shelf
H	4	Machine Locator
I	4	M6 Split Lock Washer
J	4	M6 x 16mm Button Head Screw

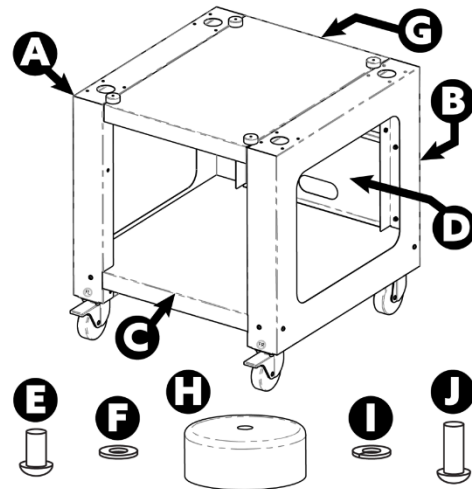

Prior to assembly of the Cart, place cardboard or a blanket on the floor to prevent damaging Cart parts.

Stage 1 – Attaching the Base Support

- Place items A and B (Cart Leg Assemblies) on the floor with the Casters facing up. The Casters with the brake face the front of the Cart.
- Assemble Item C (Base Support) into the cut outs (see arrows) located on each side of both Cart Legs, Items A and B.
 - For a shelf configuration, orient the smooth face of item C (Base Support) facing the top of the cart.
 - For a tray configuration, orient the smooth face of item C (Base Support) facing the bottom of the Cart.
- Install (6 each) items E and F (M6 x 12mm Screw and M6 Washer) at locations shown. Assemble loosely, do not tighten.
- Fully tighten all (6) item E Screws.

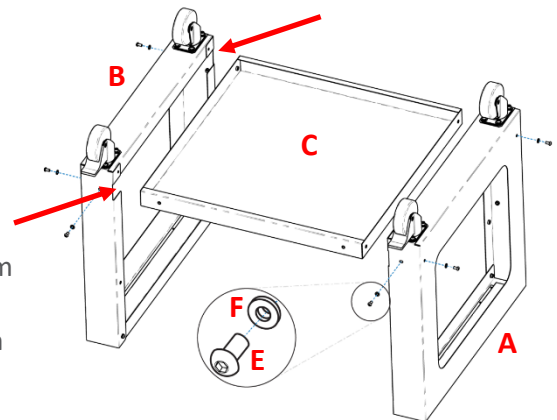

Stage 2 – Installing the Rear Support

- Rotate the Cart to its upright position.
- Assemble Item D (Rear Support) to the rear side of the Cart, with the obround opening facing towards the bottom of the cart, resting on item C (Base Support).
- Install (4 each) items E and F (M6 x 12mm Screw and M6 Washer) at locations shown. Assemble loosely, do not tighten.
- Fully tighten all (4) item E Screws.

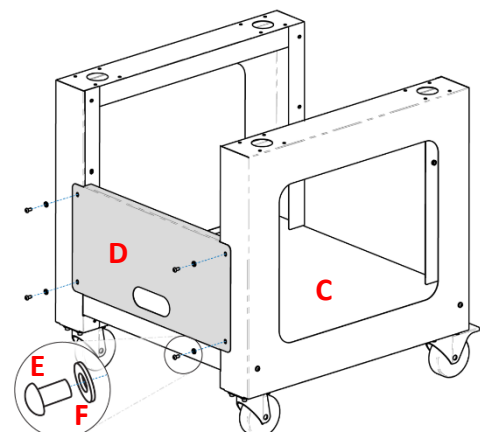

Stage 3 – Installing the Cart Shelf - OPTIONAL

Installation of item G (Cart Shelf) is optional. It can be installed in the upper or the middle positions as shown.

1. Position item G (Cart Shelf) in the desired upper or middle location, as shown.
 - For a shelf configuration, orient the smooth face of item G (Cart Shelf) facing the top of the Cart.
 - For a tray configuration, orient the smooth face of item G (Cart Shelf) facing the bottom of the Cart.
2. Install (4 each) items E and F (M6 x 12mm Screw and M6 Washer) at locations shown. Assemble loosely, do not tighten.
3. Fully tighten all (4) item E Screws.

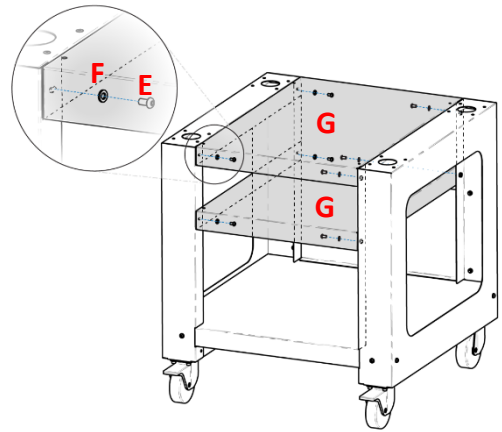

Assembly of the Cart is now complete.

Using the Handles to Place Machine on Cart

1. Locate the box containing the Lift Handles and unpack the Handles. The box is labeled with the following:

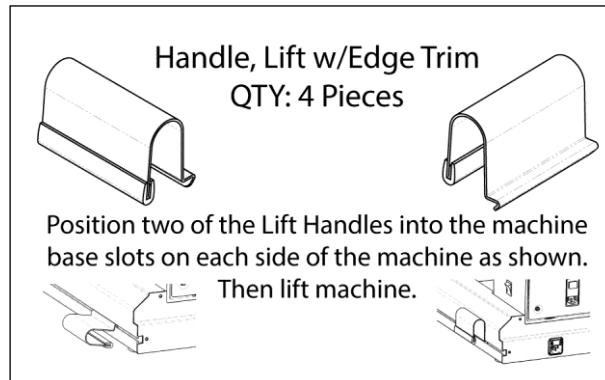

2. Position two of the Lift Handles into the machine base slots on each side of the machine as shown below. They will secure as the Handle is tilted up. On each leg, one Handle should be close to the front and the other close to the back of the machine.

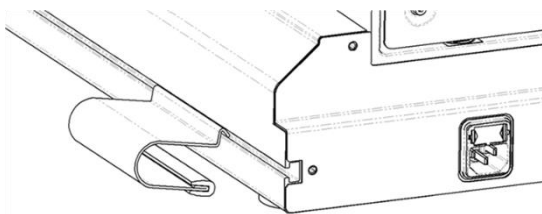

To place the Handle, align the angled edge to the T-channel in the leg of the machine base.

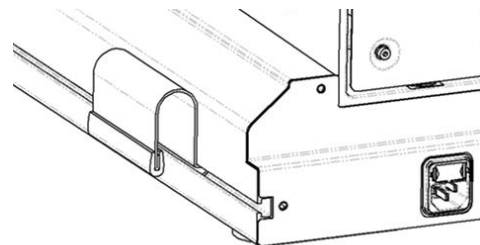

Rock forward and lift slightly up on the Handle to rotate it into place.

3. With two people, lift the machine using the Handles on both sides of the machine.

Do not attempt to lift the machine by yourself. Always move the machine with two people. Do not lift the machine at any points other than the Lift Handles placed as described above. Otherwise, damage to sensitive parts might result.

4. Place the machine on the assembled Cart so that the Rubber Feet of the machine fall into the holes on the tops of the Machine Cart.

Make sure the back support of the Cart is to the back and the Locking Casters are in front.

Installation of User Interface and X-Beam End Caps

1. Locate the box containing the User Interface and X-Beam End Caps. The box is labeled with the following:

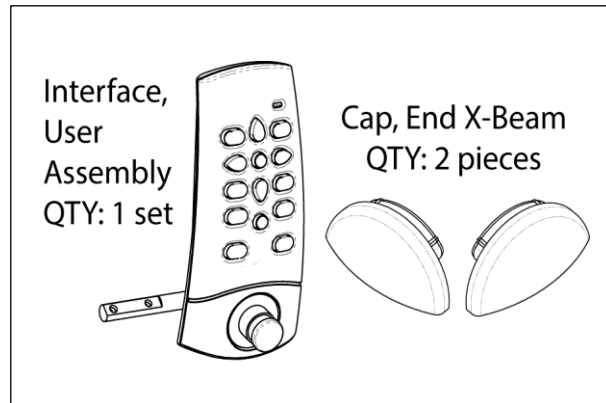

2. Attach the User Interface Assembly.

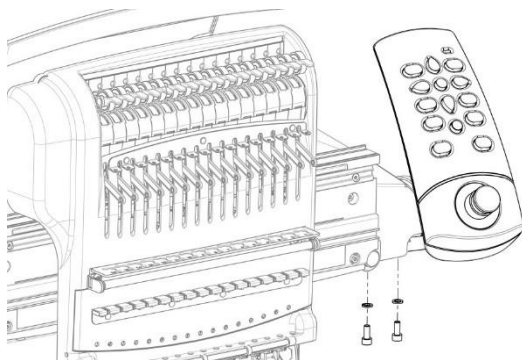

Using the two screws and two lock Washers that came with the User Interface Assembly, attach the Interface as shown in the image using a 4mm hex wrench (provided in the Machine Operator's Kit).

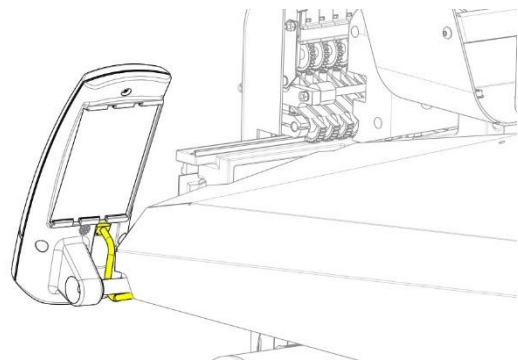

Route the network cable (shown in yellow) from under the right-side Machine Cover, under the User Interface Mounting Bolt, and plug into the back of the User Interface Assembly.

3. Insert the X-Beam End Caps on either side of the X-Beam as shown in the image below.

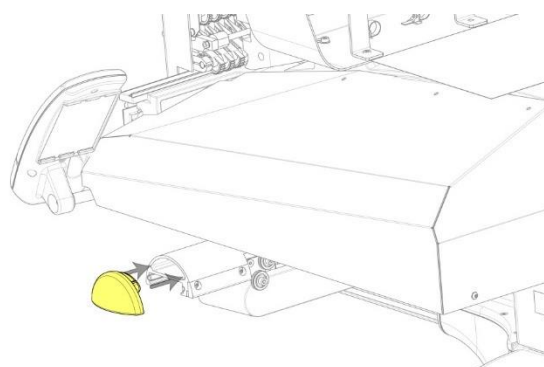

Melco OS Software – First Time Installation Instructions

1. Download the Melco Operating System Software from the web address provided on the software license card included in the software package (part of your machine shipment).
2. Double-click the downloaded installation program.
3. A dialog box will appear. Click “Continue” to accept the License Agreement and continue the installation.

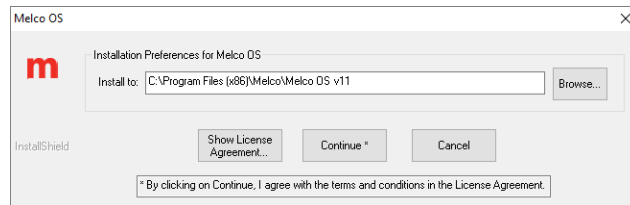

4. During installation a security popup may come up. Please check “Always trust software from “Melco International LLC” and click “Install”.

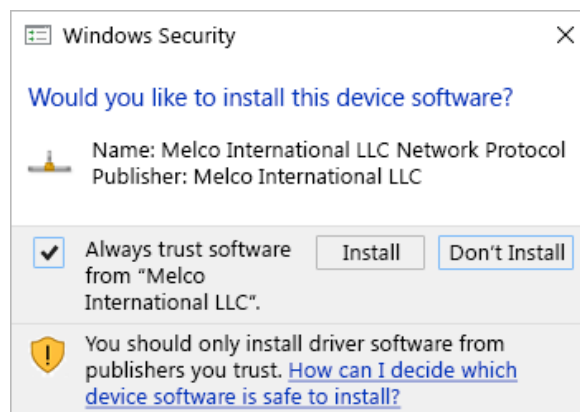

5. After the installation, a final dialog box will appear. Click “Finish” to complete the installation and close the installation wizard.

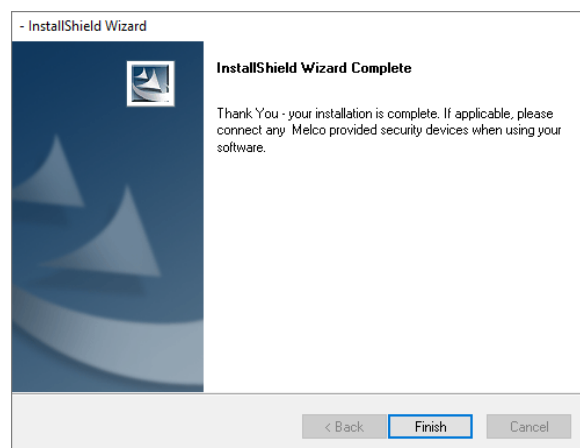

6. Launch the Melco OS software from the icon on the desktop and follow the on-screen instructions for activating your software.
7. Once the Melco OS software has been launched and activated, **press the question mark icon to access the help documentation.** Use the first part of the document to complete the machine setup.

Melco OS – Software Activation

When you initially launch your software, you will be prompted to activate the product using a product serial number (see “Product Activation” below).

Melco OS may be installed on multiple computers, but only one activated software is allowed at one time. One activation is allowed per product serial number at any given time.

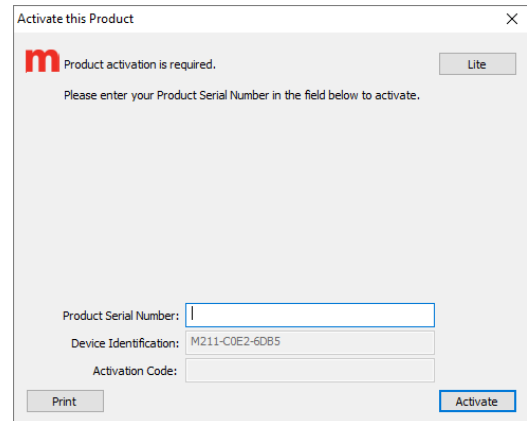

Lite

If the product is not activated, it can run in Lite mode.

Lite is a version of the software that allows for the running of the machine, but limits are applied to sew field, sew speed, and various other settings. It will also force the software into the Melco OS Advanced Interface.

To run in Lite, click on the Lite button on the first Product Activation page.

Product Activation

In the initial activation page that comes up when you launch the software, enter the following information:

- Product Serial Number - This is printed on the card in the software package provided with the machine. **Do not lose this number.**
- Device Identification Number - This number will be generated by the software and entered for you.
- Activation Code - If you are connected to the Internet, you may attempt to automatically obtain this number by clicking the Activate button. This is the fastest and easiest way to activate your software.



If you are not connected to the Internet, follow the on-screen instructions to obtain an activation code through an alternative Internet-enabled device.

Product Deactivation

To deactivate the software and free the license for use on another device, follow the steps below. Access the product deactivation page using one of the following methods:

- Go to Tools>Deactivate Product.
- Go to Tools>Security, and click on the Deactivate button in the General tab.

Follow the on-screen instructions and retain the deactivation code.

Melco OS – Connection Between Computer and Machine

Before a connection can be established between the computer and the machine, the appropriate connection port must be selected in the software.

1. Launch the software by double clicking or double tapping the Melco OS icon on your desktop.

2. Tap the Settings button to navigate to the Settings screen. 

3. Tap the Advanced Settings button to navigate to the Advanced Settings screen. 

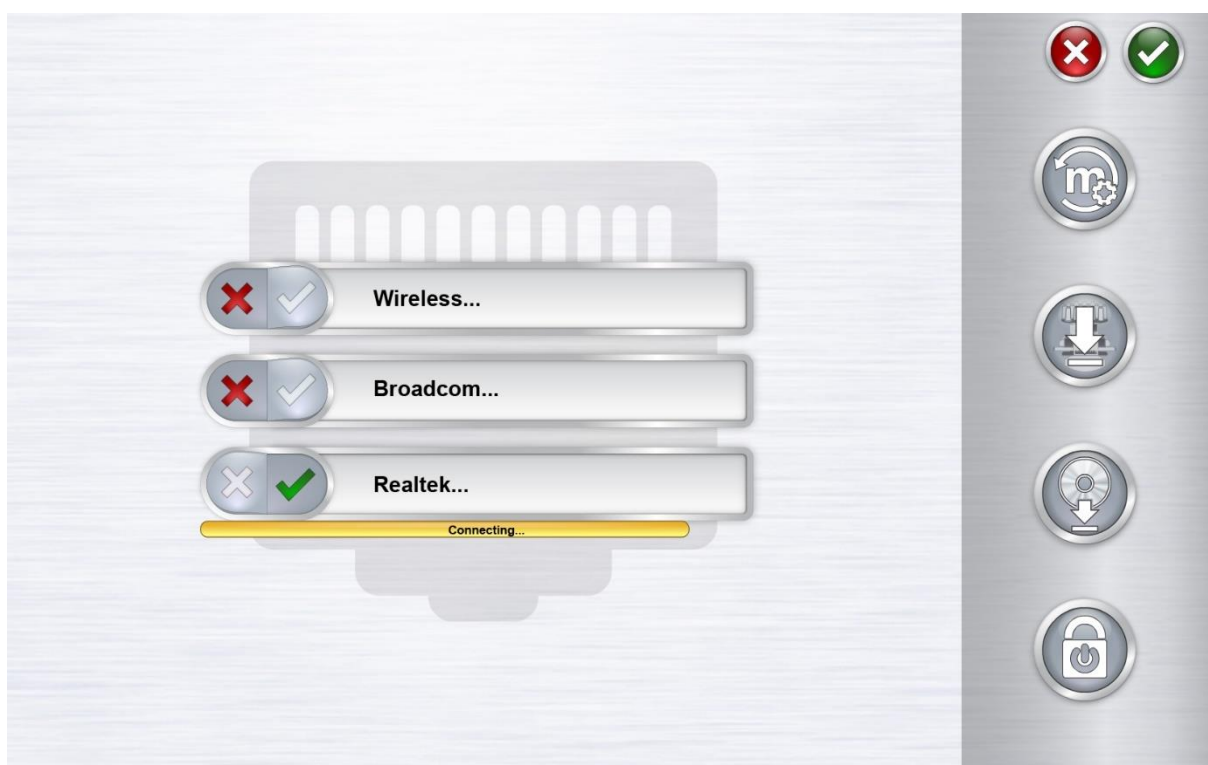

4. Select the connection the machine is going to use from the connections list (shown above) by tapping the check mark to the left of the connection name. A progress bar will display the connection status.
5. As the port is connecting, move on to powering up the machine. If the machine does not completely initialize before the progress bar finishes, the status may indicate that a connection is not found. This should remedy itself after the machine fully initializes.

Machine Initial Power Up Sequence

1. Make sure that all the machines are turned off.
2. Make sure the software is launched and the Main Screen is being displayed.
3. Make sure the E-Stop is disengaged by turning it in the direction of the arrows.



4. Power up the machine with the power switch.



5. The software will load firmware files to the machine, and the machine will initialize and display on screen.

Please note that the first time the machine is powered up and connected to the software, it may take 90-120 seconds for the machine to fully initialize and appear on screen. The Hoop Arms must first move from the shipping position to the home position before the machine can initialize.

Safety Instructions Reference

IMPORTANT!

Before installing your machine, please read the Safety Information located in the Operators Manual online at <http://www.melco-service.com>.

WICHTIG!

Vor Installation Ihrer Maschine lesen Sie bitte die Sicherheitshinweise, die Sie online im Bedienerhandbuch unter <http://www.melco-service.com> finden.

IMPORTANT!

Avant d'installer votre machine, veuillez lire attentivement les instructions de sécurité qui se trouvent sur ligne au manuel d'utilisation à <http://www.melco-service.com>.

¡IMPORTANTE!

Antes de instalar su máquina, le rogamos lea las instrucciones de seguridad que se encuentran online en el manual del operador en <http://www.melco-service.com>.

IMPORTANTE!

Prima di installare la macchina, leggere le Norme per la Sicurezza del Manuale d'Uso on line su <http://www.melco-service.com>.

TÄHTIS INFO!

Enne masina paigaldamist lugege läbi ohutusnõuded kasutajamanuaalist aadressil <http://www.melco-service.com>.

SVARBŪ!

Prieš mašinos montavimą, perskaitykite saugumo nurodymus, kuriuos Jūs rasite valdymo vadovylyje internetiniame puslapyje <http://www.melco-service.com>.

VIGTIGT!

Før installation af Jeres maskine, venligst læs sikkerhedsbestemmelser, som De finder online i betjeningsvejledning under <http://www.melco-service.com>.

BELANGRIJK!

Voor u uw machine installeert, dient u de veiligheidsinstructies te lezen. U vindt deze online in het gebruikershandboek onder <http://www.melco-service.com>.

TÄRKEÄÄ!

Lue turvallisuusohjeet ennen koneen asennusta . Löydät ne käyttöohjeista osoitteesta <http://www.melco-service.com>.

PENTING!

Sebelum menginstal mesin Anda, bacalah petunjuk-petunjuk untuk keselamatan kerja yang dapat Anda baca secara online dalam manual di <http://www.melco-service.com>.

Safety Instructions Reference

중요!

기계를 설치하시기 전에 온라인 사용설명서 <http://www.melco-service.com> 에 있는 안전상의 주의사항을 잘 읽으십시오.

VAŽNO!

Prije instaliranja Vašeg stroja molimo pročitajte sigurnosne upute, koje možete naći online u uputi za upotrebu na <http://www.melco-service.com>.

VAŽNO!

Prije instaliranja Vaše mašine molimo pročitajte sigurnosne upute, koje možete naći online u uputi za upotrebu na <http://www.melco-service.com>.

PENTING!

Sebelum pemasangan mesin anda, sila baca maklumat keselamatan yang tersedia di dalam buku panduan di laman web <http://www.melco-service.com>.

VIKTIG!

Før installasjon av din maskin må du lese sikkerhetshenvisningene som du finner online i instruksjonshåndboka på Internett-adressen: <http://www.melco-service.com>.

UWAGA WAŻNE!

Przed zainstalowaniem swojej maszyny, proszę przeczytać „Wskazówki dotyczące bezpieczeństwa”, znajdujące się online w instrukcji obsługi na stronie <http://www.melco-service.com>.

IMPORTANTE!

Antes da instalação de sua máquina, por favor leias as informações de segurança que se encontram online no Manual de instruções no site <http://www.melco-service.com>.

ВНИМАНИЕ!

Перед установкой Вашей машины прочтите инструкции по безопасности к машине, которые Вы найдете в руководстве по эксплуатации в сети Интернет по адресу: <http://www.melco-service.com>.

УВАГА!

Перед встановленням Вашої машини прочитайте інструкції з безпеки до машини, які Ви знайдете в керівництві з експлуатації в мережі Інтернет за адресою: <http://www.melco-service.com>.

DÔLEŽITÉ!

Pred inštaláciou vášho stroja si prečítajte bezpečnostné pokyny pre stroj, ktoré nájdete online v príručke pre obsluhu stroja na stránke <http://www.melco-service.com>.

ПОМЕБНО!

Pred instaliranjem vašega stroja prosimo preberite varnostna navodila, ki jih najdete v uporabniškem priročniku na spletni strani <http://www.melco-service.com>.

Safety Instructions Reference

VIKTIGT!

Innan du installerar din maskin, vänligen läs säkerhetsanvisningarna som finns i användarhandboken online på <http://www.melco-service.com>.

ÖNEMLİ!

Makinenizin enstalasyonundan önce lütfen online olarak <http://www.melco-service.com> adresi altında bulunmakta olan Kullanıcı Kılavuzundan Güvenlik Uyarılarını okuyun.

QUAN TRỌNG

Trước khi lắp máy, yêu cầu quý vị hãy đọc thông tin an toàn trong sách hướng dẫn phụ tùng theo địa chỉ trên mạng như sau: <http://www.melco-service.com>.

ΣΗΜΑΝΤΙΚΟ!

Πριν από την εγκατάσταση του μηχανήματός σας, σας παρακαλούμε να διαβάσετε τις ενδείξεις ασφαλείας, που θα βρείτε στο διαδίκτυο στο εγχειρίδιο στο <http://www.melco-service.com>.

DŮLEŽITÉ!

Před instalací Vašeho stroje si prosím přečtěte Bezpečnostní pokyny, které najdete online v Příručce k obsluze na adrese: <http://www.melco-service.com>.

重要!

在安装您的 机之前，请先阅读 安全操作说明。安全操作说明的内容在 操作使用手册中，请查阅如下网页 <http://www.melco-service.com>。

هام!

قبل تركيب ماكينة الرجاء قراءة تعليمات الأمان في دليل المستخدم المتوفر في موقع الانترنت بعنوان <http://www.melco-service.com>

EG/EC**Konformitätserklärung ♦ Declaration of Conformity
♦ Déclaration de Conformité ♦ Dichiarazione di Conformità****Wir ♦ We ♦ Nous ♦ Noi**Melco International LLC

(Name des Herstellers) (Manufacturer's name) (Nom du fournisseur) (Nome del produttore)

1575 W. 124th Ave., Westminster, CO 80234 / USA

(Anschrift) (Address) (Adresse) (Indirizzo)

erklären in alleiniger Verantwortung, dass das Produkt ♦ declare under our sole responsibility that the product ♦ déclarons sous notre seule responsabilité que le produit ♦ dichiariamo sotto la nostra unica responsabilità che il prodottoStickmaschine/ embroidery machine/ machine à coudre/ macchine per cucireMELCO EMT16X, BRAVO

(Bezeichnung Typ oder Modell, Los-, Chargen- oder Seriennummer, möglichst Herkunft und Stückzahl)

(Name, type or model, lot, batch or serial number, possibly sources and numbers of items)

(Nom, type ou modèle, no de lot, d'échantillon ou de série, éventuellement sources et nombre d'exemplaires)

(Nome, tipo o modello, numero di unità o di serie, eventualmente wogo di origine e numero di esemplari)

auf das sich diese Erklärung bezieht, mit der/den folgenden Norm(en) oder normativen Dokument(en) übereinstimmt: ♦ to which this declaration relates is in conformity with the following Standard(s) or other normative document(s): ♦ auquel se réfère cette déclaration est conforme à la (aux) Norme(s) ou autre(s) document(s) normatif(s): ♦ alla quale si riferisce questa dichiarazione di conformità e conforme con la/le norme/l o altri/o documento/i:EN 60204-1:06 + A1 :09, EN ISO 14121-1 :07, EN 60204-31:98, EN 62471 :08, EN60825-1 :07

(Titel und/oder Nummer sowie Ausgabedatum der Norm(en) oder der anderen normativen Dokumente)

(Title and/or number and date of issue of the Standard(s) or other normative document(s))

(Titre et/ou no et date de publication de la (les) norme(s) ou autre(s) document(s) normatif(s))

(Titolo e/o numero e data di pubblicazione della/le norme/l o altri/o documento/i)

Gemäss den Bestimmungen der Richtlinie(n) ♦ following the provisions of Directive(s) ♦ conformément aux dispositions de(s) Directive(s) ♦ in conformità alle disposizioni direttiveMachinery Directive 2006/42/EC, EMC Directive 2014/30/EC, RoHS Directive 2011/65/EC**und auf dem Gemeinschaftsmarkt in Verkehr gebracht wird durch: ♦ and placed into circulation on the community market by: ♦ et est placé en circulation sur le marché de communauté par: ♦ e si porta in circolazione sul mercato comunitario tramite:**Westminster, CO / USA, June 13, 2019

(Ort und Datum der Ausstellung)

(Place and date of issue)

(Lieu et date)

(wogo e data)

Matthias Kondler, COO/VP, Head of Engineering and Operations

(Name und Unterschrift oder gleichwertige Kennzeichnung des Befugten)

(Name and signature or equivalent marking of authorized person)

(Nom et signature du signataire autorisé)

(Nome e firma del firmatario autorizzato)